

amt  
**postpro**<sup>®</sup>



**postprodp** **STUDIO**

**COMPACT  
DEPOWDERING  
SYSTEM DESIGNED  
FOR SMALLER  
PART SIZES AND  
STUDIO OPERATING  
ENVIRONMENTS**

V1.0

\*SPECIFICATIONS SUBJECT TO CHANGE

## CERTIFICATIONS

The POSTPRO DP STUDIO is ATEX certified class II 3 / -D T125°.

## FOOTPRINT

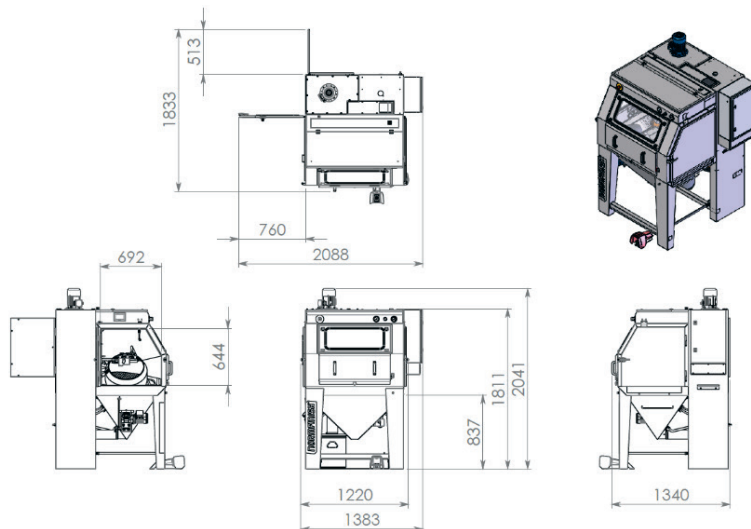

The POSTPRO DP STUDIO is constructed in one compact unit, incorporating the blasting area and cyclone to minimize the machine footprint. It was specially designed to be used for blasting 3D printed polymer parts.

## TECHNICAL SPECIFICATIONS

Description	EU	US
<b>External dimensions (w x d x h):</b>	1383 x 1340 x 2041 mm	55 x 53 x 80 in
<b>Effective blast room (w x d x h):</b>	1105 x 800 x 800 mm	43 x 31.5 x 31.5 in
<b>Working height:</b>	840 mm	33 in
<b>Door openings (w x h) (2 pieces):</b>	692 x 640 mm	27 x 25 in
<b>Basket with plastic lining and mixers:</b>		
• Dimensions	Ø450 x 210 mm	Ø17.7 x 8.27 in
• Maximum load (depends on product size and shape)	10 litre	10 liter
• Loading weight	10 kg	22 lbs
<b>View window left door (w x h):</b>	450 x 300 mm	17.7 x 11.8 in
<b>View window (w x h):</b>	656 x 266 mm	25.6 x 10.23 in
<b>Silica carbide blast nozzle:</b>	Ø8 mm	0.31 in
<b>Filter cartridges (polyester, M-class):</b>	1 filter cartridge of 4 m <sup>2</sup>	1 filter cartridge of 4 m <sup>2</sup>
<b>Capacity ventilator:</b>	600 m <sup>3</sup> /h (0,75 kW)	353 cfm
<b>ATEX classification:</b>	<b>Class II 3/-D T125°C</b>	<b>Class II 3/-D T125°</b>
<b>Dust emission:</b>	< 1,8 mg/Nm <sup>3</sup>	< 1,8 mg/Nm <sup>3</sup>
<b>Lighting:</b>	LED light 20 Watt	LED light 20 Watt
<b>Electrical connection:</b>	230V, 50 Hz.	220V, 60Hz
<b>Total power consumption:</b>	0,85 kW	0,85 kW
<b>Air consumption at 6 bar and 8 mm nozzle:</b>	60 m <sup>3</sup> /h	35.5 cfm
<b>Cabin weight (complete):</b>	ca. 430 kg	948 lbs
<b>Noise level:</b>	Low noise level due to the installed silencer (<79dB(A) at 3 bar).	

## SYSTEM DESCRIPTION

### BASKET:

The POSTPRO DP STUDIO is equipped with a steel basket containing a soft basket lining. The basket dimensions are  $\varnothing 450$  x 210 mm with an effective volume of 10 liters.

### ADJUSTABLE ANGLE & NOZZLE HOLDER:

The basket angle can be manually adjusted to achieve optimum results for different part geometries and loads. The system includes an adjustable holder for the blast gun and blow off nozzles.

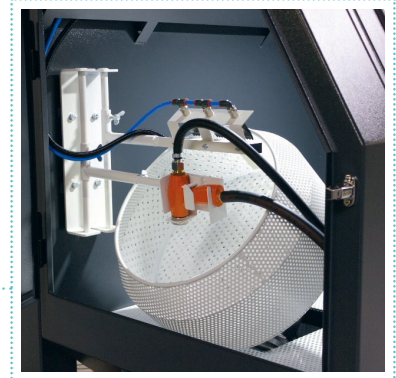

### USER INTERFACE:

Equipped with a touch screen HMI for easy parameter adjustment of the blasting process and machine status information.

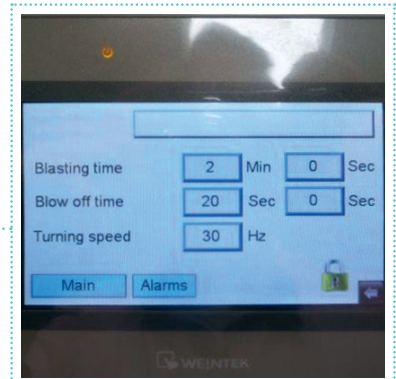

### DOOR SAFETY:

The heavy duty doors are designed with a sandwich construction to ensure a tight seal against the blasting chamber. Safety switches have been installed to ensure the machine cannot be operated when a door is open.



**CHAMBER OBSERVATION:**

A large front mounted window consists of a safety glass and a secondary splash glass which can be easily removed and replaced.



**CYCLONE:**

Equipped with a built in cyclone for efficient blast media cleaning and a constant operating mixture. An additional filter has also been installed to prevent the mixing chamber from clogging.



**EXTRACTION:**

A ventilator with a high extraction rate has been installed to prevent dust build up in the blasting chamber and improve visibility during operation. The filters are cleaned automatically with an adjustable cleaning pressure to suit different media and applications.

**DUST BIN:**

The dust from the filter unit is collected in a sealed dust bin for quick and clean waste removal.

**MANUAL BLASTING:**

The POSTPRO DP STUDIO is equipped with a manual blasting option, typically used when cleaning larger parts.

Manual blasting is possible by removing the front mounted gloves cover, taking the blast gun from the gun holder, and operating the foot pedal.

The gloves cover incorporates a safety lock so it is not possible to start an automatic process when the front mounted gloves cover has been removed.



**IONIZATION UNIT:**

The POSTPRO DP STUDIO is equipped with an ionization unit to further reduce static build up within the blasting process. The ionization unit results in 'dust free' products with no need for any additional cleaning steps once the process has finished.

This ionization unit is ATEX certified.

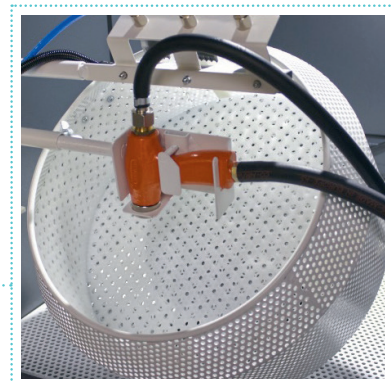

## BLAST MEDIA

The cabinets are suitable for all common abrasives such as corundum, glass beads, ceramics, nut shells, plastic and fine grain sizes of stainless steel and steel.

The blast media is recycled and separated from the dust and contaminants in the in-built cyclone.

To determine which abrasive is most suitable for your process, AMT can perform tests and provide advice free of charge.

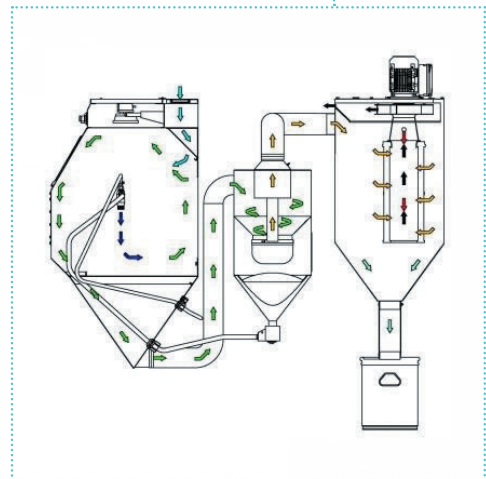

## WARRANTY

The warranty period is 12 months after delivery and applies to material and construction defects. Parts subject to normal wear and tear are excluded from this.

In the event of a warranty case, the parts will be sent free of charge.

The compressed air must be clean and dry and must comply with ISO8573.1 class 4.

Products to be blasted must also be dry and free of grease.



## CONTACT INFORMATION

For further information please contact AMT:

[info@amtechnologies.com](mailto:info@amtechnologies.com)

EU: +44 114 3122 3344

US: +1 512 352 9393

## AFTER SALES SUPPORT:

[support@amtechnologies.com](mailto:support@amtechnologies.com)

